

Wide Dynamic Range ATM Surveillance Camera Sheet



504+TVL High Resolution

* DC Power Only

Parts of ATM Surveillance Camera

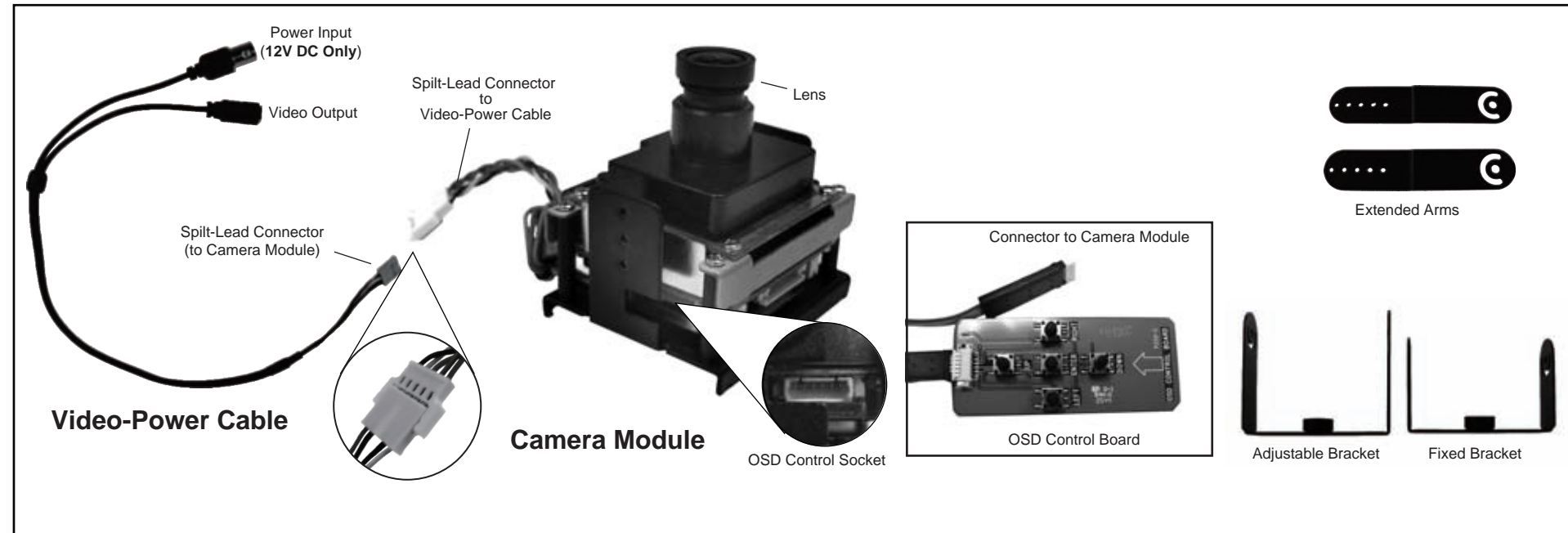

Camera Installation and Programming

Installation

Choose the appropriate bracket from the two included (Adjustable or Fixed).

To change the bracket, remove the screws on each side of the camera, remove the current installed bracket and replace with the new version. Reinstall the attaching screws to secure the bracket to the camera.

For specific locations there are two extended arms to extend the length of bracket.

1. Remove the bracket by loosening the securing screws and axis screws in both sides.
2. Place the two extended arms and secure the supplied axis screws to the camera. Then replace the positioning screws onto the camera.
Note: slightly tighten the axis screw and make sure the extended arms are loosely rotatable.
3. Reinstall the bracket onto the extended arms with the axis screws; then secure positioning screws.
4. Adjust the position required and tighten the positioning screws so as to fix the camera to the desired view angle.

Note: Some installations will require the bracket to be installed in the ATM machine before attaching the camera to the bracket. Do Not Over Tighten

Once the camera is mounted and positioned, secure the camera by tightening screws

Connect the cable from the camera module into the split lead connector of the Video-Power cable. Next use the wire ended barrel plug to attach to the appropriate power source and plug into the mating connector of the Video-Power cable.

Alternatively, a 12VDC PSU terminated with a 2.1mm DC jack may be used instead of the barrel connector. Video connection is made to the BNC connector of the Power Video Lead.

Caution: 12VDC ONLY

Make sure power is off before connecting camera.



Remove the bracket out of the camera.



Keep the extended arms rotatable while securing the axis screws.

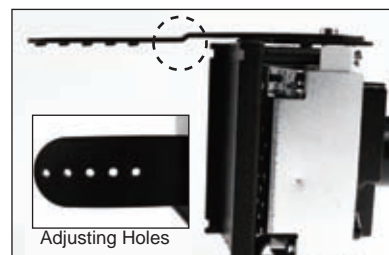

Place the extended arms and secure the axis screws to both sides.

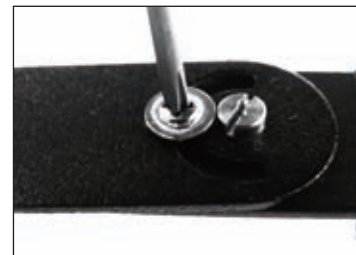

Loosely secure the positioning screws on the camera.



Replace the bracket onto extended arms by positioning on the adjusting holes desired.



Adjust the extended arms and bracket then tighten the positioning screws to fit the camera on to the location.

Bracket Adjustment

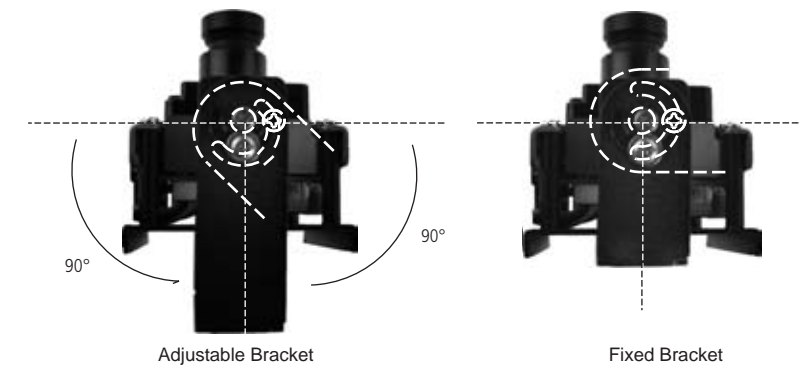

Adjustable Bracket

Fixed Bracket

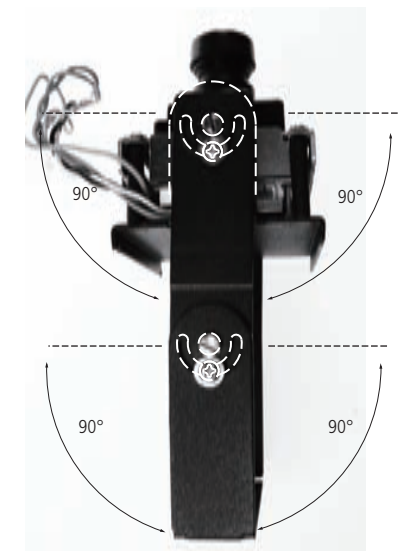

Bracket with Extended Arms

Connect the OSD Control Board and Programming

Connect the OSD connector to Camera in the OSD Control Socket (see image below).



Connecting OSD Control Board to the Camera Module

With power applied to the camera and a video monitor connected, press and hold the [ENTER] key for three seconds to access the top level menu. A map of the menu options are shown in the back of this sheet.

To navigate through the menus, use the arrow keys on the control board and use the [ENTER] key to select the required menu field.

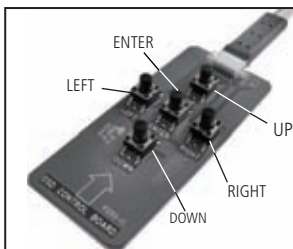

IMPORTANT:

When you make changes to the camera configuration, you MUST save them using the "SAVE SETTINGS" option in the "SAVE/RESTORE" menu. Otherwise any changes made will be lost when the camera is next reset or has its power cycled.

Control Menu Map

Press the [ENTER] key on the control board for three seconds to view the menu.

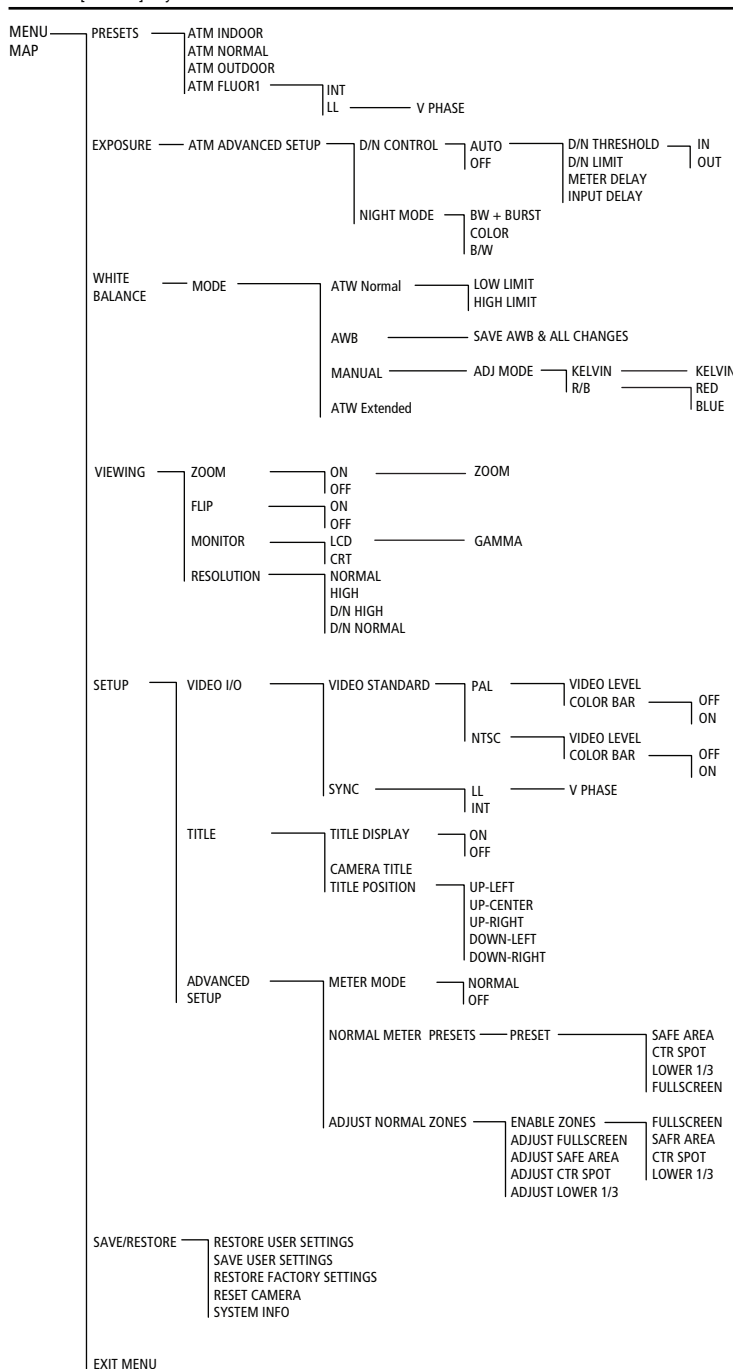

Menu Description

PRESETS – There are "factory set" general configurations. Select the preconfigured mode for the camera to use to give the best performance for the specified environment. Pressing the [ENTER] key on the selected option will display the pre-configured set-up parameters.

ATM NORMAL – This should provide the most versatile settings for general purpose applications.

ATM INDOOR or **ATM OUTDOOR** – These settings are optimized for indoor/outdoor lighting conditions.

ATM FLOUR1 – This setting can be used to help reduce the Flicker effects of this type of lighting.

LL (Line Lock) – Sync is locked to the AC supply cycle and permits adjustment of V-phase, to correct for vertical sync picture roll. (Applicable for 24VAC supply only. If a 12 volt DC power supply is used the camera will run in INT.)

EXPOSURE– **ATM ADVANCED SETUP** –This mode enables camera to acquire better images under Daylight or low light conditions.

This mode enables camera to acquire better images under Daylight or low light conditions.

D/N CONTROL -This feature may be used to improve low light performance by reducing noise from the video signal.

AUTO – In reduced lighting, camera switches automatically to Night (black & white) mode and back to Color once the ambient lighting returns to normal levels.

OFF – Forces the camera into Day (Color) only mode regardless of lighting conditions.

NIGHT MODE – This feature selects the camera performance under low light condition.

WHITE BALANCE- **WHITE BALANCE** has 4 modes for selection. Each mode process electronic shutter differently and is suitable for different environment.

ATW Normal – Selects a normal Auto White Balance Range, for general operation. If necessary the range is configurable with low limit (to help with reds) and high limit (to help with blues) adjustments.

AWB –Auto White Balance.

MANUAL – Allows manual setting of the color temperature of the image. This can be achieved by using the Kelvin option, by which ever method the installer is familiar with. This setting is also good for static environment applications where the lighting conditions never change, like indoor hallways.

ATW Extended – Extended Auto White Balance Range – use this setting for scenes that may have an extremely wide range of color temperature.

VIEWING

ZOOM – Variable zoom up to 3x.

FLIP – Mirror Image.

MONITOR – Select output devices: LCD or CRT.

RESOLUTION – Adjust video output.

SETUP

VIDEO I/O – The function enables video frequency and sync setup.

TITLE – The camera can be named and displayed when operating.

ADVANCED SETUP

NORMAL METER PRESETS - These are factory set general configurations to choose from. If adjustments are needed for a zone goes to Adjust Normal Zones to reconfigure.

ADJUST NORMAL ZONES - This feature is used to configure the area used for WDR light metering. Tapping the [ENTER] key reveals a box which is the WDR zone. Repeatedly tapping the [ENTER] key changes the color of the zone.

White - Move entire zone's position.

Green - Used to increase the size of the zone.

Red - Used to reduce the size of the zone.

Use the arrow keys to adjust the zone position or size. Holding the [ENTER] key for 3 seconds returns you to the previous menu. The default setting will provide good general performance. If adjustment is necessary, size according to the area of interest making sure to include all areas of interest. This will dictate how the overall wide dynamic range features operate.

Example:

An internal scene viewing a doorway and polished floor. Daylight often streams through the doorway. It is required to see people entering the doorway and follow them to the left hand side of the picture. The doorway is central to the image. The box should be sized and positioned to cover the doorway and the area to the left where people walk.

SAVE/RESTORE

RESTORE USER SETTINGS – This will undo any changes made since the last "Save Setting".

SAVE USER SETTINGS – Save any programming changes to ensure they are retained after power loss or reset. If changes are not saved, the camera will revert to the previous settings on power-up.

RESTORE FACTORY SETTINGS – Restore camera settings to factory default – full reset, all previous program will be lost including video standard which will default to NTSC.

RESET CAMERA – This is a soft reset and has the same effect as cycling the camera power.

SYSTEM INFO – Displays the camera firmware version.

EXIT MENU

Select and exit OSD menu when the setup is complete. Make sure the user setting is saved before exit.

ATM Camera Specifications

Image Picture Element	Pixim Orca Sensor
Effective Picture Element	720(H) x 540(V)
Resolution (TV lines)	504+
Minimum Illumination	0.95 Lux @ F1.2 (AGC Boost)
S/N Ratio	>42dB
Wide Dynamic Range	120 dB / 17bit
Wide Dynamic Range Area	1 Zone - Fully Adjustable
Slow Shutter	Default 2x, max 32x
Electronic Shutter	1/50 or 1/60 ~ 1/100000
Day/Night	SDN Auto/On/Off
White Balance	ATW, MWB, 1-Touch
Auto White Balance Range	2200°K ~ 7500°K, 2000°K ~ 11000°K
Sync System	Internal/Line lock 57Hz - 62.4Hz for NTSC 47.5Hz - 52Hz for PAL
Video Output	1.0Vpp, 75 ohm Unbalanced
Power Range	12VDC -10% +20%
Power Consumption	4.2W (Max)
Operating Temperature	-10°C to +50°C
Storage Temperature	-20°C to +60°C

Lens Specifications

Focal Length	2.9mm
F-No.	F2.0
Iris Range	Fixed Range
Dimensions	Ø14.5X18.5 mm
Diagonal	122.1°
Angle Of View : Horizontal	96.6°
Vertical	71.9°

Regulatory Compliance

Emissions FCC part 15 Class B

CE: EN55011

ICES-003

EN55022

CISPR 11

CISPR22

ANSI C63.4

Immunity CE: EN50130-4

Safety CSA C22.2

UL60065



FCC COMPLIANCE:

This equipment complies with Part 15 of the FCC rules for intentional radiators and Class B digital devices when installed and used in accordance with the instruction manual. Following these rules provides reasonable protection against harmful interference from equipment operated in a commercial area. This equipment should not be installed in a residential area as it can radiate radio frequency energy that could interfere with radio communications, a situation the user would have to fix at their own expense.

CISPR 22 WARNING:

This is a Class B product. In a domestic environment this product may cause radio interference in which case the user may be required to take adequate measures.

POWER SUPPLY REQUIREMENTS:

For use with listed Audio/Video Product and only connected to 15W or less power supply. Power supply should be a NEC Class 2 / LPS Supply.

EQUIPMENT MODIFICATION CAUTION:

Equipment changes or modifications not expressly approved by seller, the party responsible for FCC compliance, could void the user's authority to operate the equipment and could create a hazardous condition.