

High Resolution Fixed Lens Indoor Dome Camera Sheet

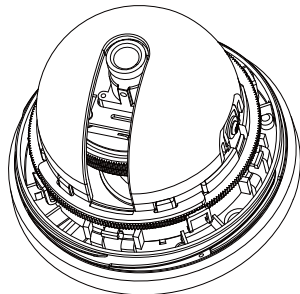

500 TV Line
Color Camera



About this Sheet

Thank you for purchasing this product.
Before operating this unit, please read this sheet carefully to know more about it.

This sheet introduces a high resolution camera, featuring the following:

- 500TVL

For detailed descriptions about the unit's specification, please refer to the following content. Information provided in this sheet include package contents, regulatory compliance, camera specifications, lens specifications, camera illustrations and so on so as to help you know better about this unit.

Please note that the specifications and appearance of this unit are subject to change for further improvements without prior notice.

V531-DF011-000
Ver. 08/2009

Hardware Kit Contents

- 1/2" Rubber Grommet
- 3/4" Rubber Grommet
- Screw Pack
- Torx Driver
- Quick Install Adaptor (Optional)
- Wire-ended Power Adaptor lead

Regulatory Compliance

Emissions	FCC part 15 Class B CE: EN55011 ICES-003 EN55022 CISPR 11 CISPR22 ANSI C63.4
Immunity	CE: EN50130-4



FCC COMPLIANCE:

This equipment has been tested and found to comply with the limits for a Class B digital device, pursuant to Part 15 of the FCC Rules. These limits are designed to provide reasonable protection against harmful interference in a residential installation. This equipment generates uses and can radiate radio frequency energy and, if not installed and used in accordance with the instructions, may cause harmful interference to radio communications. However, there is no guarantee that interference will not occur in a particular installation.

If this equipment does cause harmful interference to radio or television reception, which can be determined by turning the equipment off and on, the user is encouraged to try to correct the interference by one or more of the following measures:

- Reorient or relocate the receiving antenna.
- Increase the separation between the equipment and receiver.
- Connect the equipment into an outlet on a circuit different from that to which the receiver is connected.
- Consult the dealer or an experienced Radio/TV technician for help.

CISPR 22 WARNING:

This is a Class B product. In a domestic environment this product may cause radio interference in which case the user may be required to take adequate measures.

POWER SUPPLY REQUIREMENTS:

For use with listed Audio/Video product and only connected to 15W or less power supply.
*Power supply should be a NEC Class 2 / LPS Supply.

EQUIPMENT MODIFICATION CAUTION:

Equipment changes or modifications not expressly approved by seller.
The party responsible for FCC compliance could void the user's authority to operate the equipment and could create a hazardous condition.

This class B digital apparatus complies with Canadian ICES-003.

Cet appareil numérique de la classe B est conforme à la norme NMB-003 du Canada.

Camera Specification

In the following table, you may find information about the specification of this camera. Please refer to the specific item for the data you require.

Type / Format	NTSC	PAL
Scanning Element	2:1 Interlace, H15.734KHz / V :59.9Hz	2:1 Interlace, H15.625KHz / V :50Hz
Image Picture Element	1/3" Interline CCD	
Effective Picture Element	768(H) x 494(V)	752(H) x 582(V)
Resolution (TV lines)	500	
Minimum Illumination	1.2 Lux @ F1.6	
S/N Ratio	48dB	
Back Light Compensation	Central Area for DC IRIS Lens	
Exposure Control	DC Type Auto IRIS Control	
Sync System	INT	
Gamma Compensation	0.45	
Video Output	1.0Vpp, 75 Ω Unbalanced	
White Balance	Automatic White Balance	
Auto White Balance Range	2500°K – 9700°K	
Power Range*	DC 12V ±10%	
Power Consumption	2.2 W (Max)	
Operating Temperature	-10°C ~ +50°C	
Storage Temperature	-20 C ~ +60°C	

Lens Specification

Focal Length	2.9mm(Fixed)	3.8mm (Fixed)	6.0mm (Fixed)	8.0mm (Fixed)	
F-No.	F2.0	F2.0	F2.5	F2.0	
Iris Range	-----	-----	-----	-----	
Minimum Object Distance	0.5m (19.7")	-----	-----	-----	
Field of View	Diagonal	122.1°	65.6°	57.8°	44.5°
	Horizontal	96.6°	52.0°	45.7°	34.6°
	Vertical	71.9°	38.7°	34.0°	25.5°

Camera Adjustment

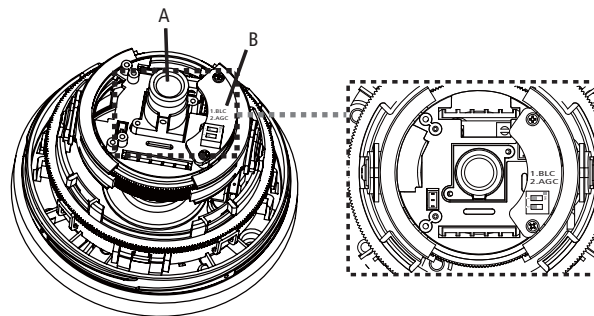

A: Fixed Focal Lens
B: Function Control Dip Switches

Function Control Dip Switches

Switch 1	Back Light Compensation	
	OFF	ON
Switch 2	Auto Gain Control	
	OFF (Normal Mode)	ON (Turbo Mode)

DIP Switch Settings for the High Resolution Series

Back Light Compensation (BLC)

When set ON, this option improves the camera's response to strong, unwanted lighting effects behind the required subject.

Low Light Sensitivity (AGC-EX/AGC-NORMAL)

When set to EX, sensitivity in low light will automatically increased. Select "NORMAL" will remove noise from the image, but it will also limit the camera's sensitivity.

Installation

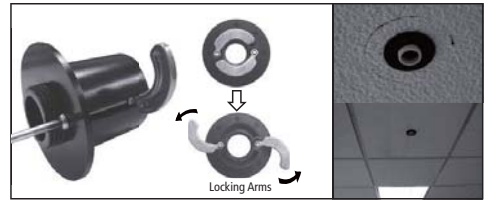
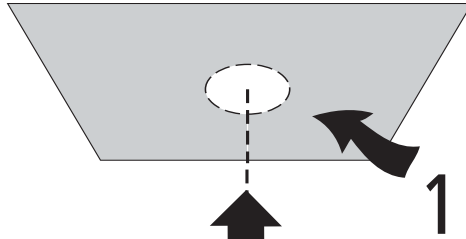

Use the quick install adaptor on a wall or ceiling application.

2 Dome Base
Mount the dome enclosure
 By using the base mounting holes, the dome base can be fixed on the wall or ceiling with attached screws.

Note: When using Quick Install Adaptor, re-assemble the parts of dome, then mount the whole dome onto adaptor (see image B).



Preparation

Preparation before installation

Use the template to mark-out and prepare the mounting area. In order to mount the base, first remove the camera module by gently pulling down on the tabs that hold the camera module in place (see image right) and remove camera assembly. To re-assemble gently pull down on the tabs and insert the camera assembly.

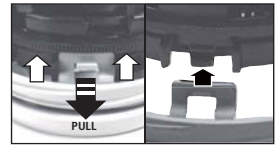

Loosen the tab and pull out the camera assembly

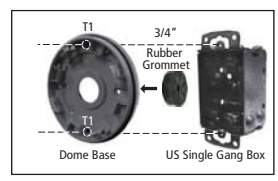
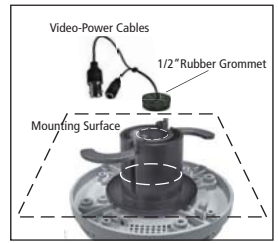
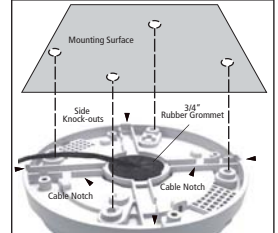

3 Camera Module
Install camera module
Push the video-power cables through the opening

Feed the pre-connected video-power cables through the appropriate point. Then push the cable out of the opening. Make sure the cable is positioned on the proper location and out of the side knock-out, if required.

Adjust the camera position
 To adjust the tilt angle, first loosen the 2 screws on the gimble (See image below) make your adjustments then retighten the screws. The focus and range of the lens can be adjusted.

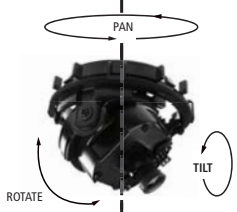

Note: Do NOT attempt to adjust the camera position by holding the lens as this will cause damage to the camera. Make adjustments by tilting and rotating the gimble assembly
 DO NOT rotate/tilt the disk beyond its maximum allowed range (350/80 degrees) or it might break.
 Please make sure the wires are positioned in a manner that allows you to rotate/pan the disk smoothly.

A. Using the base mounting holes:

When mounting the dome to a ceiling or wall using screws, first knock out the screw access holes that correspond to the template marks "T1". This can be done by using a cross-point screwdriver.

Push the cables through the dome base and 3/4" rubber grommet. Install the grommet on the base to prevent dust ingress. Cables may be routed through the mounting surface if an appropriate hole is made at location T2. If using the side knock-out, make sure the video-power cables are properly arranged in the cable notch and exit out of the side knock-out without being crushed (see image A).

B. Using the Quick Install Adaptor(Optional):

When mounting the dome to a ceiling using the quick install adaptor, use the template to cut a hole as the circle marked "T2" with a hole cutter.

Install the adaptor into the mounting surface and use the screws to adjust the position of the two locking arms on the quick install adaptor to adjust to the mounting surface.

Push the cables through the opening and 1/2" rubber grommet. Make sure the grommet is properly installed on the adaptor to prevent dust ingress (see image B).

C. Mount on a US Single Gang Box:

When mounting the dome to the box, carefully remove the screws on the box. Install the 3/4" grommet on the base to prevent dust ingress, then push the cables through the dome base and 3/4" rubber grommet. Mount the dome base on the box and reinstall the two screws. Tighten the screws sufficiently on the box (position T1, see image C).

Removing the dome cover and the camera liner

Gently turn the dome cover counter-clockwise to unlock and pull free of the dome base. Remove the camera liner by gently pulling it free of the 4 notches in the camera base (see image left).

Opening the required knock-out panel

Open one of the side knock-outs (see image A) to the size required to allow cable entry.

4 Camera Liner
Install the camera liner

Carefully fit the camera liner over the camera base so that it snaps into place, and do not obstruct the camera lens.



5 Dome Cover
Replace the dome cover
 Replace the dome cover and rotate clockwise to close it.



6 Tighten the tamper-proof screw
 Use the supplied torx driver and the tamper-proof screw (T2x5L) to secure the dome cover.



Template

Surface mount (In a wall or ceiling)

Using Quick Install Adaptor:
 Create an aperture in the mounting surface to a diameter of 1.5" (38mm) as indicated by "T2". The aperture is also available for cable access (3/4", 19mm).

Using screws:
 Create four holes at template positions "T1", use the screws and plugs provided in the screw kit where the mounting surface is appropriate.

Cable access

When the cables are threaded through the mounting surface, create an aperture indicated "T2". It can be simply threaded for use with the quick install adaptor.

When mounting the dome on a surface with the four T1 screws, use one of the side knock-outs as indicated for cable entry (see Installation Guide overleaf).

