

## Camera Adjustments and Programming

With the exception of the focus and field of view adjustments (made using levers **A** and **B**) all settings for the **WDR** series camera are made using its on screen menu display. A working video monitor and a separate plug-in control board (**C**) are required to view and select options.

1. Within the dome enclosure, first attach the service board OSD lead from the camera (F) to the middle socket of the service board. This is the split lead connection (white wire with red strips). Then connect the power connector (white wire with red strips). You will first need to replace the 6 pin split lead connector (E) with the multi colored 5 pin split lead wire that came with the WDR camera.
2. Ensure that the lead of OSD Control Board (G) is connected to the socket (D).
3. With power applied to the camera and a video monitor connected, press and hold the **ENTER** key for three seconds to access the top level menu. A map of the menu options is shown on the reverse of this sheet.
4. To navigate through the menus, use the arrow keys on the control board and use the **ENTER** key to select items. After making any changes, navigate to the **"SAVE SETTINGS"** option in the **"SAVE/RESTORE"** menu and press the **"ENTER"** key to save the changes that have been made. Otherwise any changes made will be lost when the camera is next reset or has its power cycled.
5. When configuration is complete, the OSD lead (G) may be disconnected.

## Camera Connection

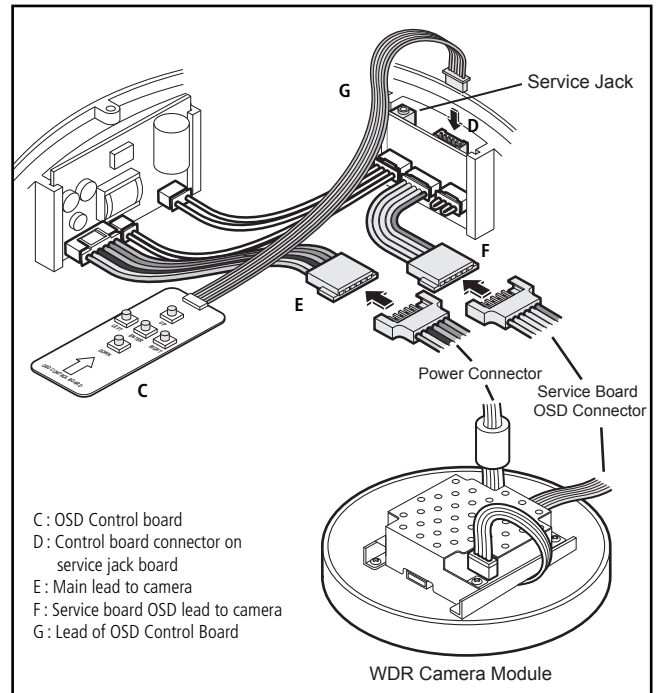

## Camera Adjustments

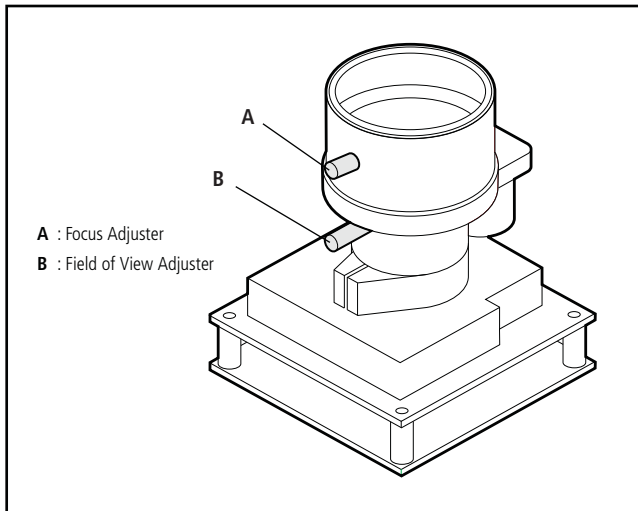

## Indoor/Outdoor Vandal Proof Dome Camera Sheet

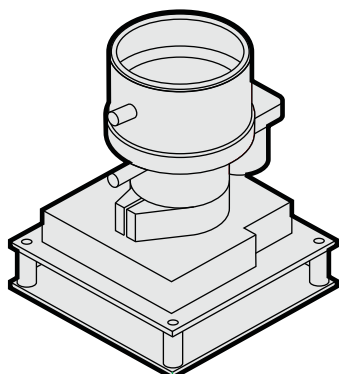

Wide Dynamic Range  
 504+TVL

## Regulatory Compliance

Emissions	FCC part 15 Class B CE: EN55011 ICES-003 EN55022 CISPR 11 CISPR22 ANSI C63.4
Immunity	CE: EN50130-4
Safety	CSA C22.2 UL60065

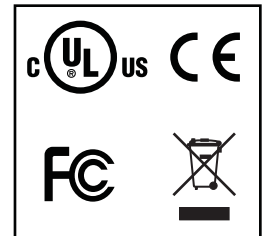

### FCC COMPLIANCE:

This equipment complies with Part 15 of the FCC rules for intentional radiators and Class B digital devices when installed and used in accordance with the instruction manual. Following these rules provides reasonable protection against harmful interference from equipment operated in a commercial area.

This equipment should not be installed in a residential area as it can radiate radio frequency energy that could interfere with radio communications, a situation the user would have to fix at their own expense.

### CISPR 22 WARNING:

This is a Class B product. In a domestic environment this product may cause radio interference in which case the user may be required to take adequate measures.

### POWER SUPPLY REQUIREMENTS:

For use with listed Audio/Video Product and only connected to 15W or less power supply. Power supply should be a NEC Class 2 / LPS Supply.

### EQUIPMENT MODIFICATION CAUTION:

Equipment changes or modifications not expressly approved by Deview Electronics Corporation, the party responsible for FCC compliance, could void the user's authority to operate the equipment and could create a hazardous condition.

## Lens Specifications (for all camera modelos)

Focal Length	2.5~6.0mm	2.9~10mm	3.0~9.0mm	3.3~12mm	9~22mm	
F-No.	F1.2	F1.2	F1.2	F1.4	F1.8	
Iris Range	F1.2~F360	F1.2~F360	F1.2~F360	F1.4~F360	F1.8~F360	
Minimum Object Distance	0.5m (19.7")	0.15m (6")	0.5m (19.7")	0.5m (19.7")	0.2m (8")	
Field Of View	Diagonal	145.5°~59.1°	125.0°~36.0°	116.2°~39.7°	125.7°~29.9°	39.0°~17.6°
	Horizontal	111.6°~47.3°	94.6°~28.8°	90.0°~31.8°	89.8°~23.9°	30.7°~14.1°
	Vertical	82.2°~35.5°	68.4°~21.6°	66.2°~23.9°	63.6°~17.9°	22.7°~10.6°
Lens Type	Aspherical	Aspherical	Aspherical	Aspherical	Aspherical	
IR Corrective Coating	Yes	Yes	Yes	Yes	Yes	

## Control Menu Map

Press the ENTER/MENU button on the control board for three seconds to view the menu.

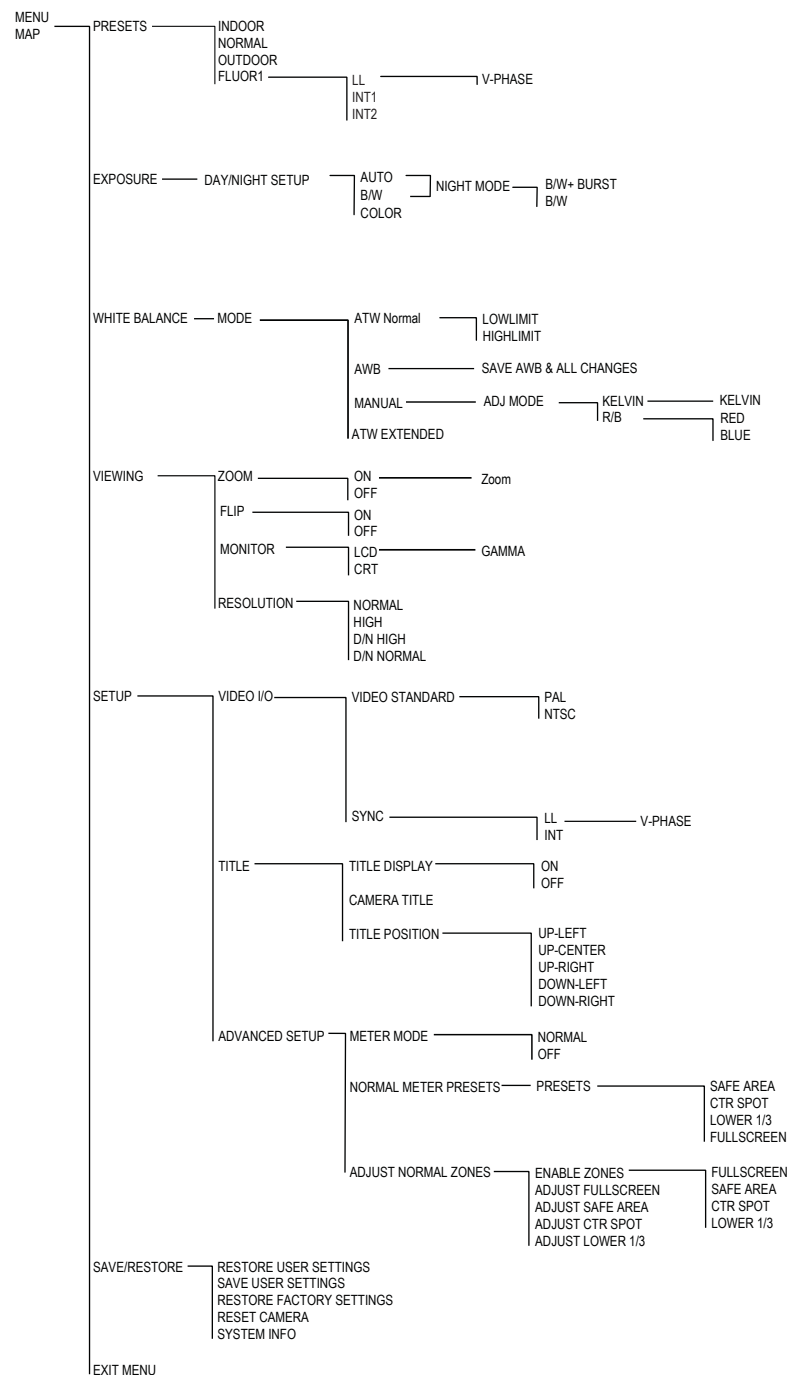

## Camera Specifications

Image Picture Element	Pixim Orca Sensor
Effective Picture Element	720(H) x 540(V)
Resolution (TV lines)	504+
Minimum Illumination	0.95 Lux @ F1.2 (AGC Boost)
S/N Ratio	>50dB
Wide Dynamic Range	120 dB/ 17 bit
Wide Dynamic Range Area	1 Zone - Fully Adjustable
Slow Shutter	Default 2x, Max 32x
Electronic Shutter	1/50 or 1/60 ~ 1/100000s
Day/Night	SDN Auto/On/Off
White Balance	AWB, MWB, 1-Touch
Auto White Balance Range	2800°K~7500°K, 2000°K~11000°K
Sync System	Internal/Line lock 57Hz - 62.4Hz for NTSC 47.5Hz - 52Hz for PAL
Video Output	1.0Vpp, 75 ohm Unbalanced
Power Range	AC: 24VAC ±20% or DC: 12VDC -10% +20%
Power Consumption	4.2W (Max)
Operating Temperature	-10°C to +50°C
Storage Temperature	-20°C to +60°C

## Menu Description

### PRESETS

There are "factory set" general configurations. Select the preconfigured mode for the camera to use to give the best performance for the specified environment. Pressing the [ENTER/MENU] key on the selected option will display the pre-configured set-up parameters. NORMAL – This should provide the most versatile settings for general purpose applications. INDOOR or OUTDOOR – These settings are optimized for indoor/outdoor lighting conditions. FLUOR1 - This setting can be used to help reduce the Flicker effects of this type of lighting. LL (Line Lock) - Sync is locked to the AC supply cycle and permits adjustment of V-phase to correct for vertical sync picture roll. (Applicable for 24VAC supply only. If a 12 volt DC power supply is used the camera will run in INT1 or INT2.)

### EXPOSURE

This mode enables camera to acquire better images under Daylight or low light conditions. AUTO – In reduced lighting camera switches automatically to Night (black & white) mode and back to Color once the ambient lighting returns to normal levels. The Night Mode is adjustable for improving low light performance. B/W – Forces the camera into Night (black & white) only mode regardless of lighting conditions. COLOR – Forces the camera into Day (Color) only mode regardless of lighting conditions.

### WHITE BALANCE

This mode has 4 modes for selection. Each mode process electronic shutter differently and is suitable for different environment. ATW Normal – Selects a normal Auto White Balance Range, for general operation. If necessary the range is configurable with low limit (to help with reds) and high limit (to help with blues) adjustments. AWB – Auto White Balance MANUAL – Allows manual setting of the color temperature of the image. This can be achieved by using the Kelvin option, by which ever method the installer is familiar with. This setting is also good for static environment applications where the lighting conditions never change, like indoor hallways. ATW Extended – Extended Auto White Balance Range – use this setting for scenes that may have an extremely wide range of color temperature.

### VIEWING

ZOOM – Variable zoom up to 3x  
FLIP – Mirror Image  
MONITOR – Select output devices: LCD or CRT.  
RESOLUTION – Adjust video output.

### SETUP

VIDEO I/O – The function enables video frequency and sync setup.  
TITLE – The camera can be named and displayed when operating.  
ADVANCED SETUP –

**Normal Meter Presets** - These are factory set general configurations to choose from. If adjustments are needed for a zone goes to **Adjust Normal Zones** to reconfigure. **Adjust Normal Zones** - This feature is used to configure the area used for WDR light metering. Tapping the [ENTER/MENU] key reveals a box which is the WDR zone. Repeatedly tapping the [ENTER/MENU] key changes the color of the zone.  
White - Move entire zone's position.  
Green - Used to increase the size of the zone.  
Red - Used to reduce the size of the zone.

Use the arrow keys to adjust the zone position or size. Holding the [ENTER/MENU] key for 3 seconds returns you to the previous menu. The default setting will provide good general performance. If adjustment is necessary, size according to the area of interest making sure to include all areas of interest. This will dictate how the overall wide dynamic range features operate. Example:

An internal scene viewing a doorway and polished floor. Daylight often streams through the doorway. It is required to see people entering the doorway and follow them to the left hand side of the picture. The door way is central to the image. The box should be sized and positioned to cover the doorway and the area to the left where people walk.

### SAVE/RESTORE

RESTORE USER SETTINGS – This will undo any changes made since the last "Save Setting".  
SAVE USER SETTINGS – Save any programming changes to ensure they are retained after power loss or reset. If changes are not saved, the camera will revert to the previous settings on power-up.  
RESTORE FACTORY SETTINGS – Restore camera settings to factory default – full reset, all previous program will be lost including video standard (return to default setting).  
RESET CAMERA – This is a soft reset and has the same effect as cycling the camera power.  
SYSTEM INFO – Displays the camera firmware version.

### EXIT MENU

Select and exit OSD menu when the setup is complete. Make sure the user setting is saved before exit.